

NOTE: FOR A 4.250" OD BACKING TUBE: MINIMUM DISTANCE BETWEEN t 'S OF ROTATION DECREASES TO 7.000" (FROM 8.000"). MINIMUM DISTANCE BETWEEN OUTSIDE TO OUTSIDE OF ENDBLOCK DECREASES TO 12.000" (FROM 13.000"). MINIMUM DISTANCE BETWEEN OUTSIDE TO OUTSIDE OF DEBRIS SHIELD DECREASES TO 13.000" (FROM 15.000").

DEBRIS SHIELD OD DECREASES TO 6.000" (FROM 7.000") AND DEBRIS SHIELD RETAINING RING OD DECREASES TO 6.348" (FROM 7.442").

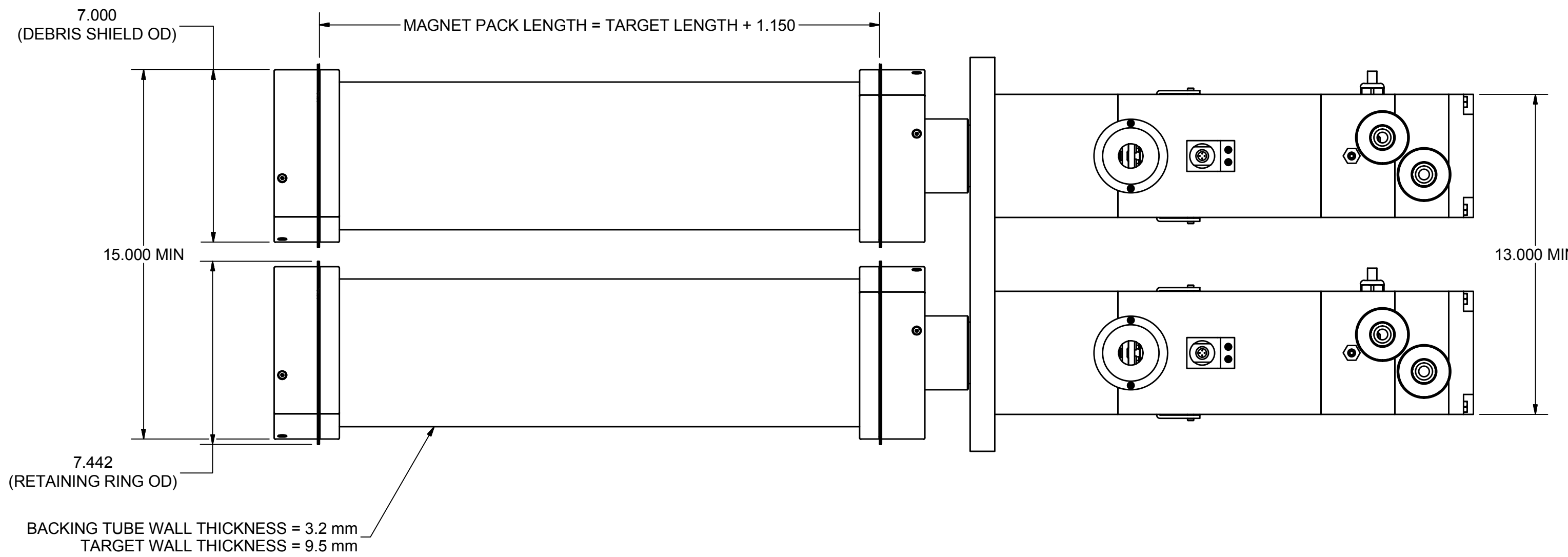

SAMPLE VALUES FOR +/- 5% UNIFORMITY					
A (SUBSTRATE WIDTH)	B (TARGET TO SUBSTRATE)	C (TARGET LENGTH)	BACKING TUBE LENGTH	MIN OVERALL LENGTH	
15.000	1.000	17.850	20.250	25.767	
15.000	1.500	19.850	22.250	27.767	
15.000	2.000	21.850	24.250	29.767	
15.000	2.500	23.850	26.250	31.767	
15.000	3.000	25.850	28.250	33.767	

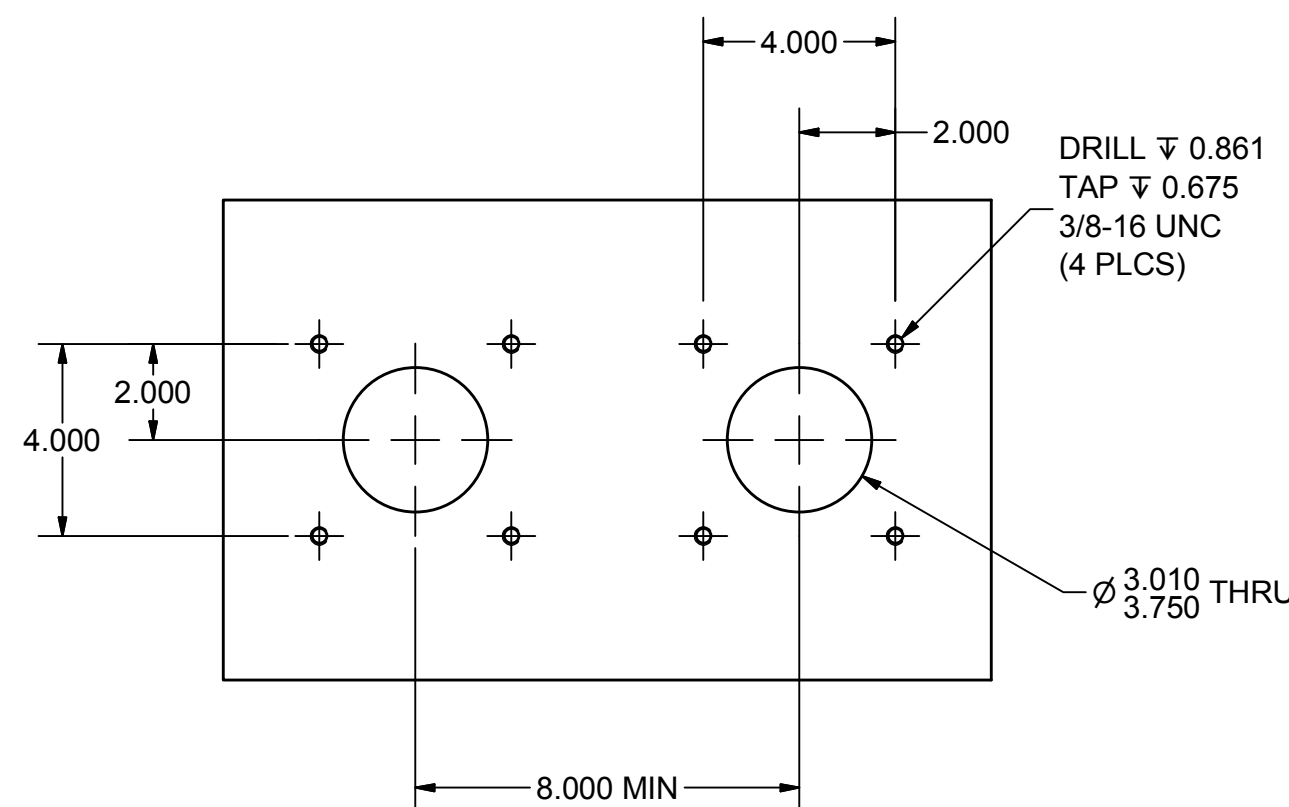

ANGSTROM SCIENCES SIDE-MOUNT CYLINDRICAL  
VERTICAL MOUNT  
UNITS: INCHES

NO.	DATE	REVISION	BY	TOLERANCES (UNLESS OTHERWISE SPECIFIED)	CONFIDENTIAL	SCALE: 1/4	ANGSTROM SCIENCES, INC.
				LINEAR (IN.) FRACTIONAL = ± 1/64 2 PLACE DECIMAL = ± 0.01 3 PLACE DECIMAL = ± 0.005 4 PLACE DECIMAL = ± 0.0005	NOTICE: THE INFORMATION CONTAINED HEREIN IS PROPERTY OF ANGSTROM SCIENCES, INC. DUQUESNE, PA AND CONTAINS PROPRIETARY INFORMATION WHICH HAS BEEN SUBMITTED TO YOU IN CONFIDENCE FOR A SPECIFIC PURPOSE. COPYING, USING, OR DISCLOSING THIS DRAWING OR THE INFORMATION ON IT WITHOUT ANGSTROM SCIENCES' PRIOR WRITTEN CONSENT BY AN APPROVED REPRESENTATIVE IS PROHIBITED AND MAY BE GROUNDS FOR LEGAL ACTION. PATENTABLE DESIGN FEATURES ARE PROTECTED BY UNITED STATES PATENT LAWS.	DRAWN BY: jlowmaster DATE: 12/7/2009	TITLE: SIDE-MOUNT CYLINDRICAL
				ANGULAR DEGREES = ± 1° DEGS. MINS = ± 00' 30"		APV: BY: DATE:	REV. SIZE: D
S:\Angstrom Inventor\1-MAGNETRON\CYLINDRICAL\SIDE-MOUNT LAYOUT\SIDE-MOUNT CYLINDRICAL (ENGLISH) - VERTICAL MOUNT.idw						SHEET 1 OF 1	PART NO.: SIDE-MOUNT CYLINDRICAL