

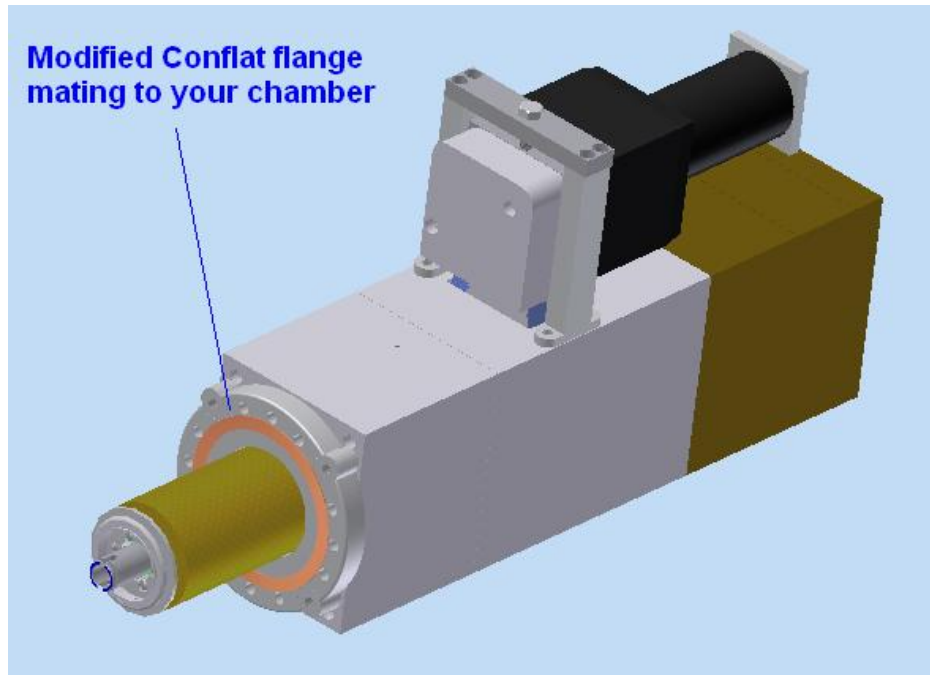

ANGSTROM SCIENCES CYLINDRICAL – FIRST INSTALLATION

1. Your cathode assembly was shipped with the interface flange temporarily secured to the cathode body. This will have to be removed and first attached to your chamber before proceeding with cathode assembly mounting.



2. When handling the cathode be careful of the placement. Typically it can be set straddling two (2) 2x4s. On the bottom of the cathode are the water inlet and outlet fitting as well as the electrical buss connection.

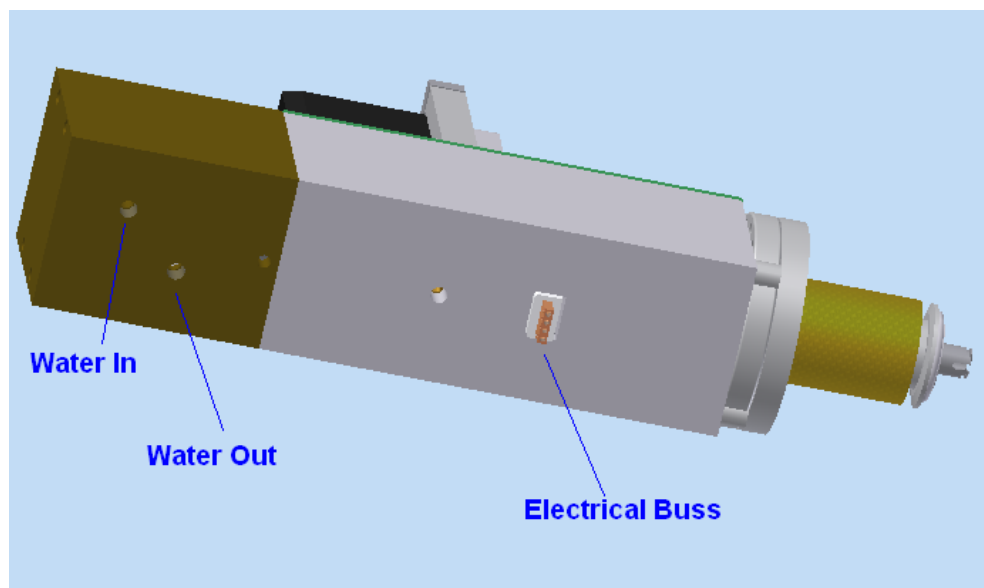



3. From the backside of the cathode, remove the four (4) 1/4-20 x 6" SHCS from the water end cap.

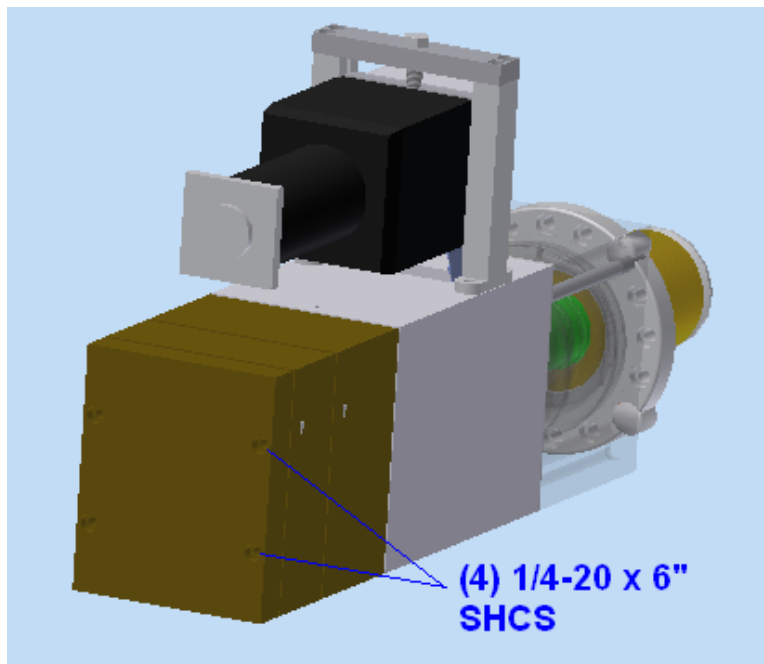

3. Carefully place aside, noting assembly and orientation, the water end cap, water inlet tubing and housing, and water seals housing. If they become dirty, the water seals can be lubricated with marine grease, which has better water resistance.

NOTE: These 3 components are already being modified to a single unit.

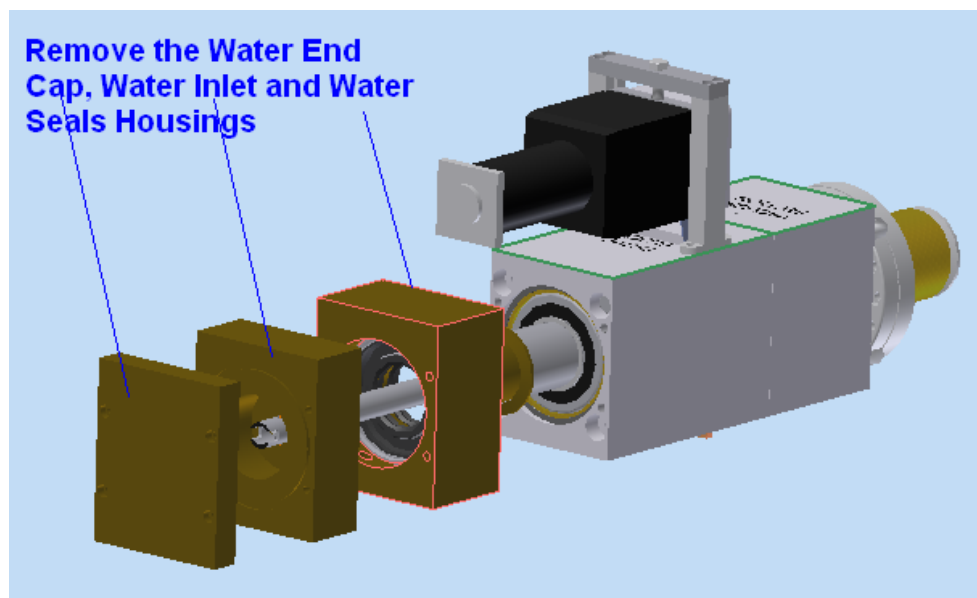

4. Remove the four (4) 3/8- 16 x 13.5" bolts which are temporarily securing your adapter flange to the cathode assembly

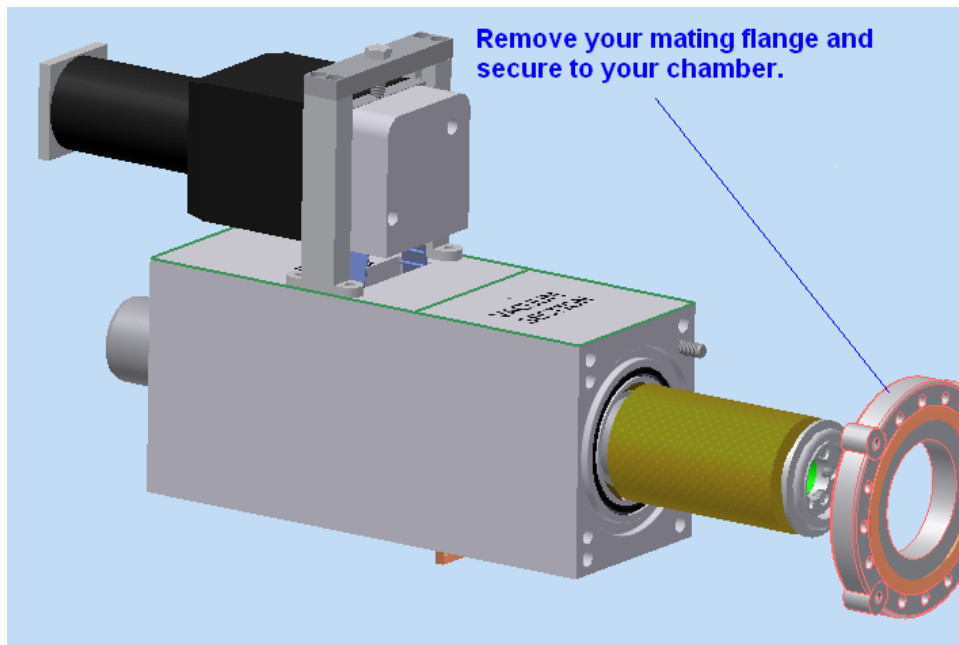
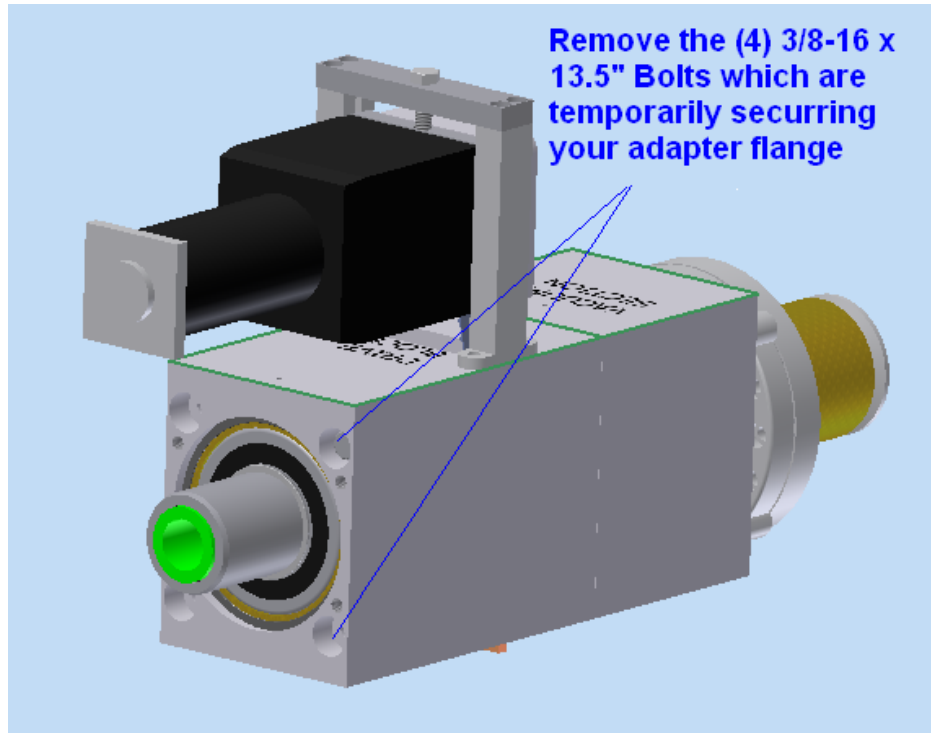

NOTE: Reassembly is completed in the reverse order of the above procedure.

NOTE: The target can also be installed, after installing the cathode, by following the directions outlined in the **Target Change Procedure**.