



CYLINDRICAL TARGET CHANGE PROCEDURES

1. After completion of the sputtering process, allow the target to run under vacuum with rotation and cooling water flow for at least 15 min.

****WARNING**** This is a safety procedure for both the target and the operator. The operator could be burned by hot target surfaces, and the target surface may be severely oxidized by quick exposure to atmosphere.
2. Upon venting the vacuum system, close the cooling water inlet and leave the outlet open.
3. With the cathode still rotating, disconnect the water inlet and allow compressed air to flow through the water-cooling channels, (or install an automatic bypass valve for compressed air) and remove as much residual cooling water as possible.

NOTE: It is advisable to place a drip pan under the NW50 flange assembly to catch the remaining water in the target tube so that contamination of the vacuum system is minimized.

4. Secure the target in suspended position by use of fixtures, cranes or other auxiliary items

NOTE: In the case of smaller target lengths, the target may be secured by hand.

5. Remove the NW50 clamp securing the target assembly to the cathode shaft. As the clamp is removed, tilt the cantilevered end of the target assembly downward to minimize the water drippings. The assembly can later be inverted at a workbench to remove all remaining amounts of water.

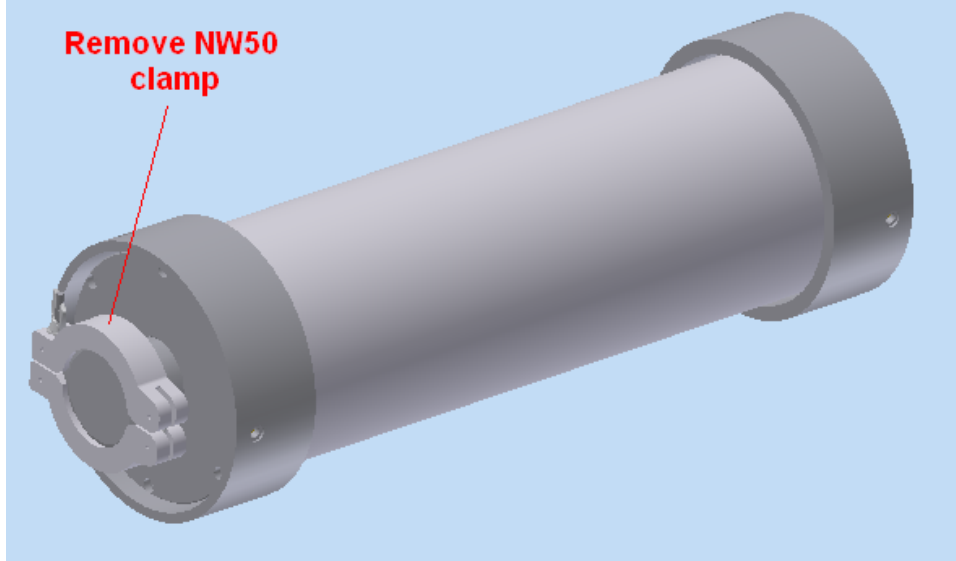

6. Remove the target assembly from the vacuum system.

NOTE: This is the time when it is advisable to have sufficient spares (magnet arrays, shields, etc.) so that the replacement target can be immediately inserted onto the cathode and system pumping can be resumed.

7. At the workbench, remove the three (3) #10 SHCS retaining the debris shield onto the assembly and slide the debris shields toward the center of the target.

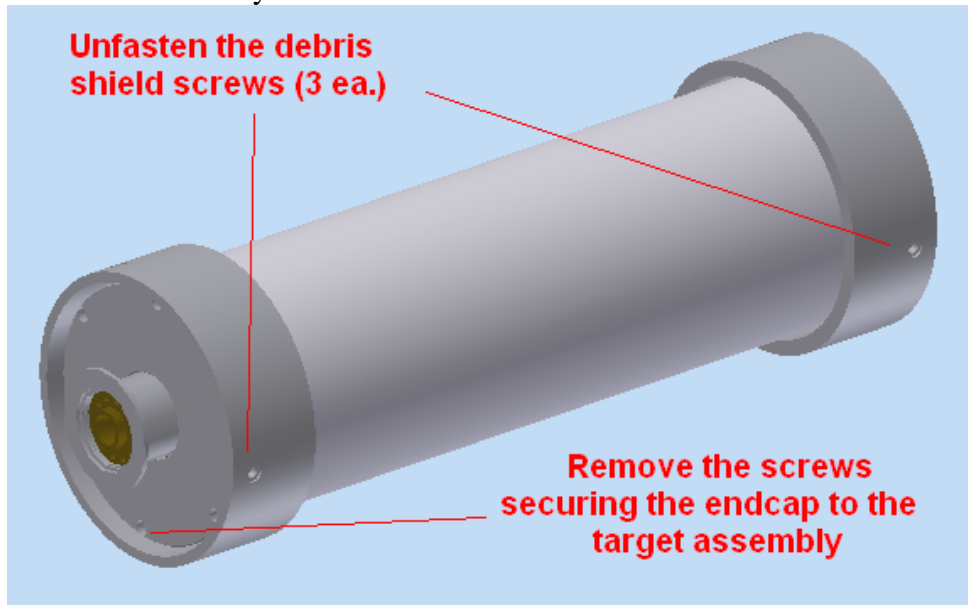

8. Remove the six (6) #10 screws securing the endcaps to the target assembly.

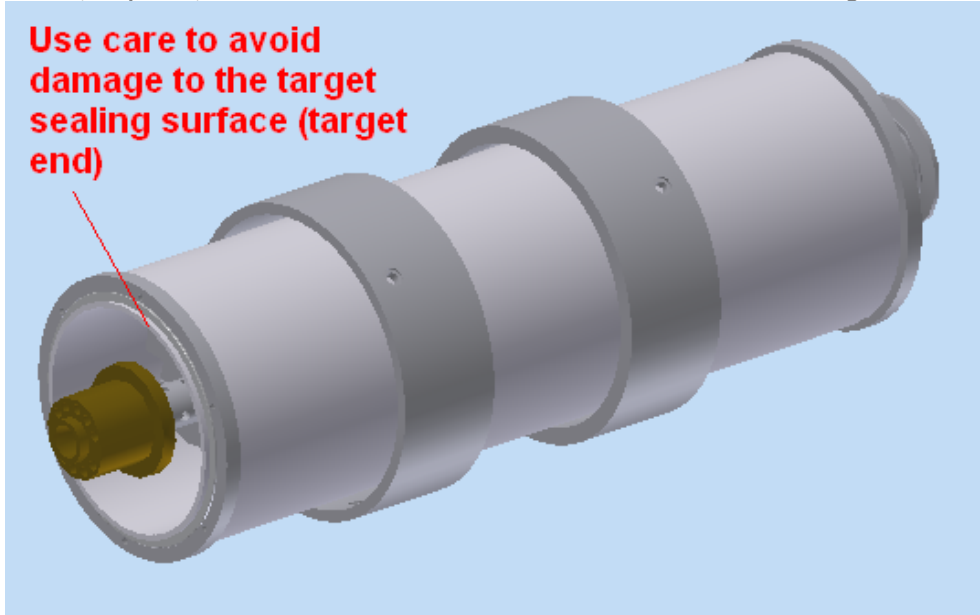

****WARNING**** The magnet array provided by Angstrom Sciences contains the highest magnetic field energy of all available rotatable magnet arrays in the market. Never place two magnet arrays in close proximity, as there is a high probability of injury to the operator. The use of steel tools in proximity to the magnet array is also not advised due to the same issues as discussed above.

9. The magnet array assembly can now be removed and transferred to the new target. If it is not to be immediately used, it is advisable to store it in a used target cylinder for safekeeping and cleanliness.

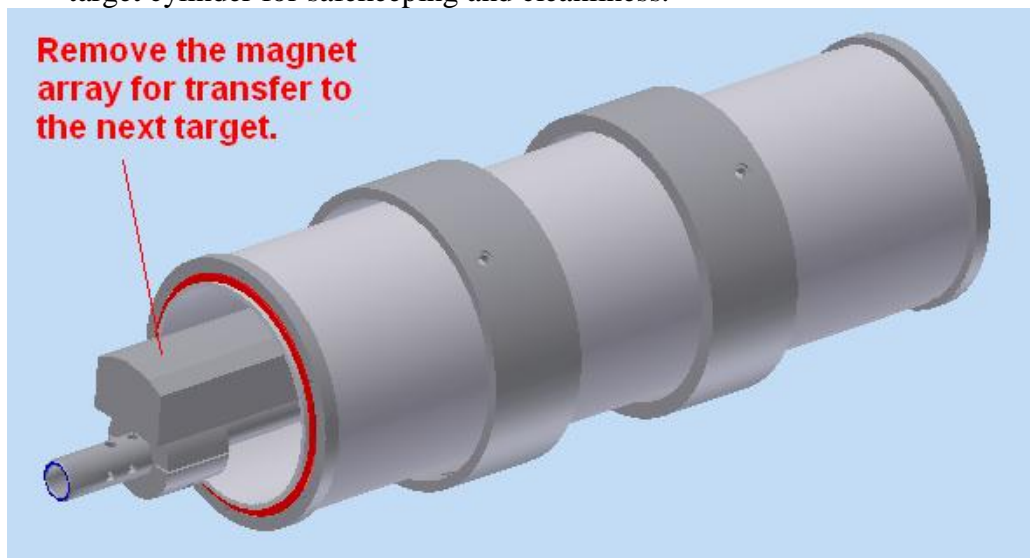

10. Remove the endcaps and the circular retaining rings located at each end of the target.

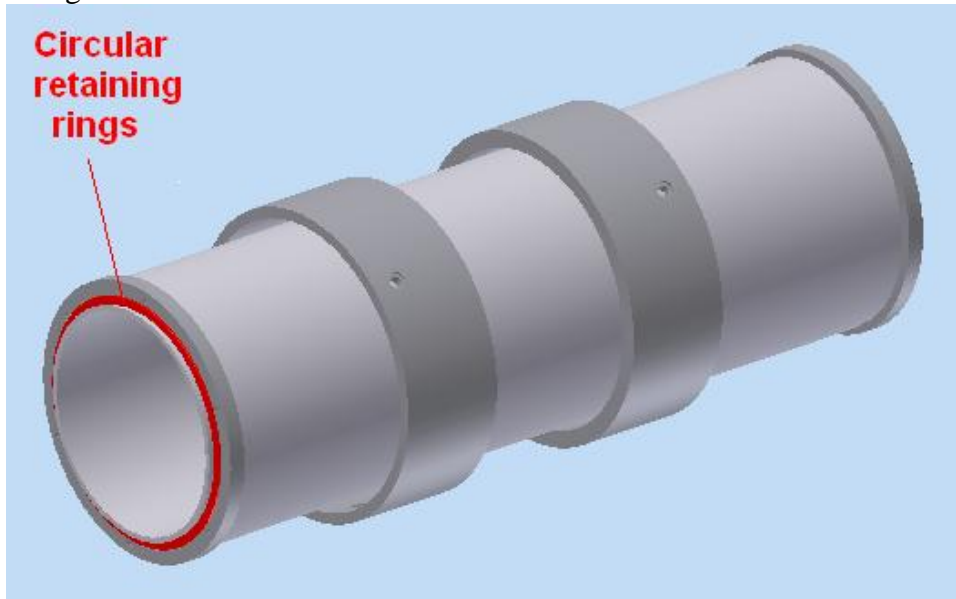

11. With the retaining rings removed, the clamp rings can now slide off the target assembly as well as the debris shields.
12. The target assembly is now completely disassembled and the target is ready to be recycled, used at a later date, or otherwise disposed of.

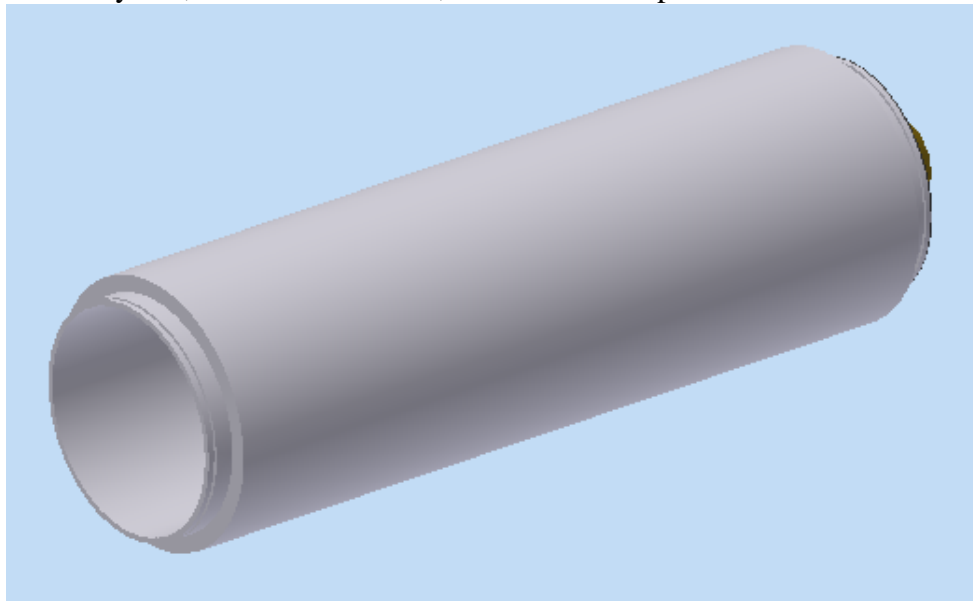

13. Prior to installing the replacement target, the operator should check all of the following for cleanliness and vacuum integrity.
 - a. Target sealing surface is free of debris, nicks and scratches.
 - b. The o-ring has been removed from the endcap, cleaned, relubricated or replaced as necessary.



- c. Debris shields have been sandblasted and cleaned.
- d. Worn or heavily coated screws have been replaced and threaded holes have been re-tapped as necessary.
- e. The debris shield insulators (T-Nuts) have been wiped clean of any potential coatings or replaced if damaged.
- f. All screws securing the endcap to the clamp rings have been tightly fastened.
- g. An ohm-meter has ensured that there is no electrical conductivity between the debris shield and any other part of the target assembly.